

RoHS Compliant

REVISIONS			
REV.	DESCRIPTION	DATE	DESIGN

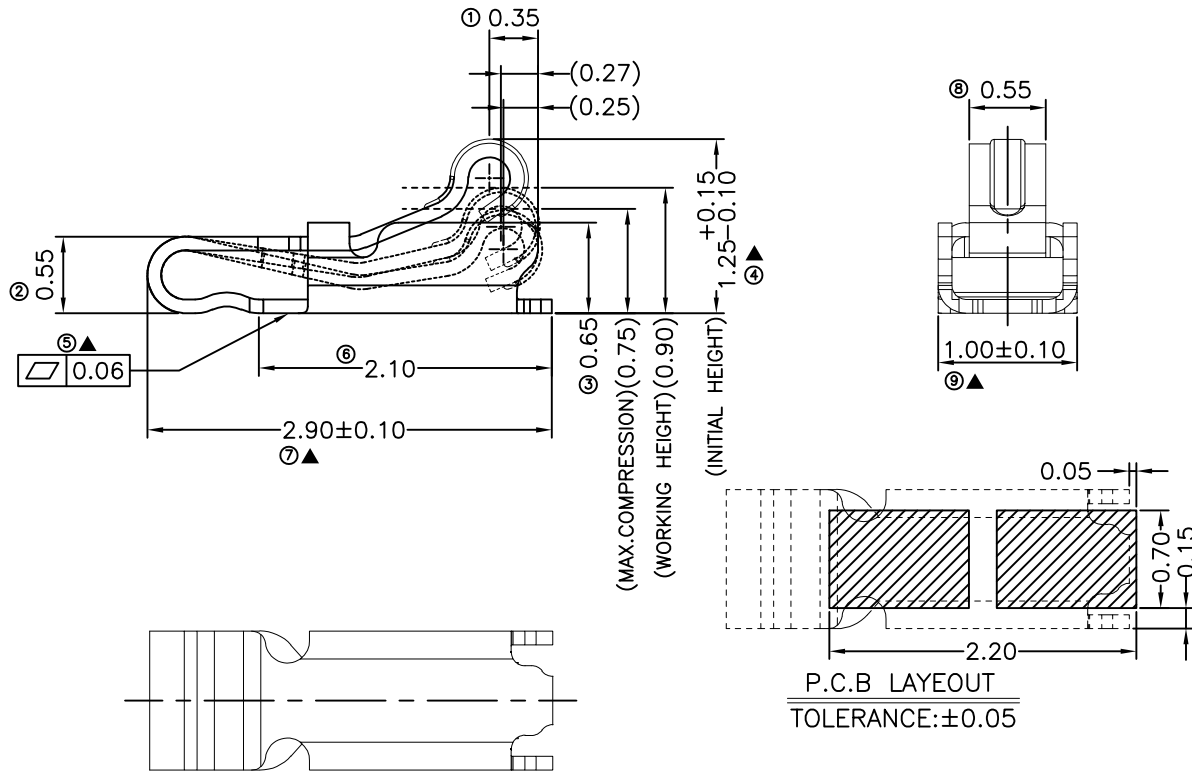

1. MATERIAL SPECIFICATION:
 - 1.1. STAINLESS STEEL SUS-301 T=0.10±0.005MM
2. TEST REQUIREMENTS:
 - 2.1. CONTACT RESISTANCE: 80mΩ MAX
 - 2.2. VOLTAGE RATING: 1.5 V/AC/DC/MAX
 - 2.3. RATED CURRENT: 1.0A/MAX
 - 2.4. WELDING THRUST: ≥3.0 Kg
 - 2.5. DURABILITY: 1,500 TIMES
 - 2.6. OPERATING TEMPERATURE: -20 ° ~ 80 ° C
3. PLATING REQUIREMENTS:
 - 3.1. OVERALL NICKEL PLATING 50U MIN, WELDING SURFACE 1U MIN GOLD PLATING, CONTACT AREA 1U MIN GOLD PLATING
 - 3.2. SALT SPRAY TEST TO MEET THE REQUIREMENTS OF 24 HOURS.
 - 3.3. TERMINAL TO EAT FULL TIN, NOT PEELING, WELDING, OBVIOUS COLOR AND OTHER ADVERSE
 - 3.4. ROHS, REACH, HF HALOGEN-FREE AND A SERIES OF DOMESTIC AND INTERNATIONAL ENVIRONMENTAL REQUIREMENTS

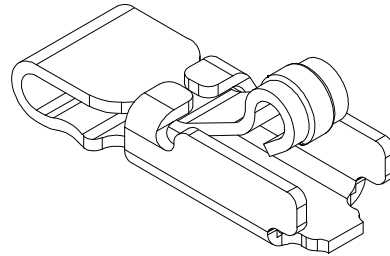
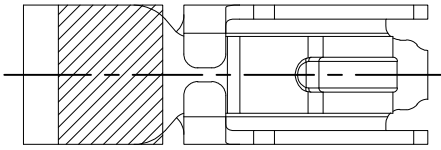
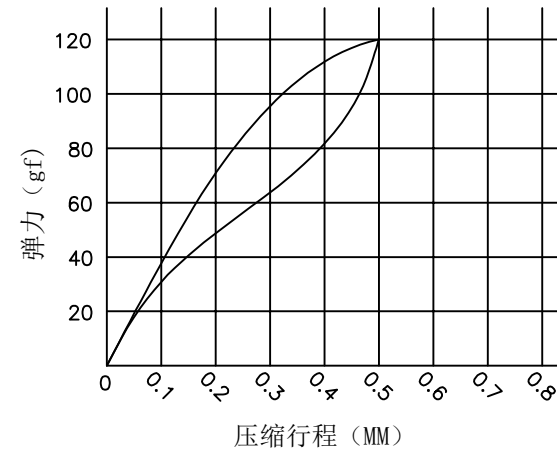

Bestcreate Technology Limited

TOLERANCES UNLESS OTHERWISE SPECIFIED:

X.	±	0.25	X."	±	3"
.X	±	0.20	.X"	±	2"
.XX	±	0.15	.XX"	±	1"

Website: www.bsc-elec.com
Email: bestcreate@bsc-elec.com

DESIGN: I.L DATE: 2017. 3. 1

CHECKED: C.W DATE: 2017. 3. 1

APPROVED: C.W DATE: 2017. 3. 1

TITLE: Antenna Shrapnel Connector
2.9*1.0*1.25H(C TYPE)

MATERIAL: AS-R5-098-0012C PART NO: AS-R5-098-0012C SIZE: A4

FINISH: AS-R5-098-0012C DWG NO: AS-R5-098-0012C

REV: A UNIT mm SCALE 1=1 QUALITY SYMBOLS